

REV.	DESCRIPTION	DATE
A	NEW DRAWING	3/29/2007

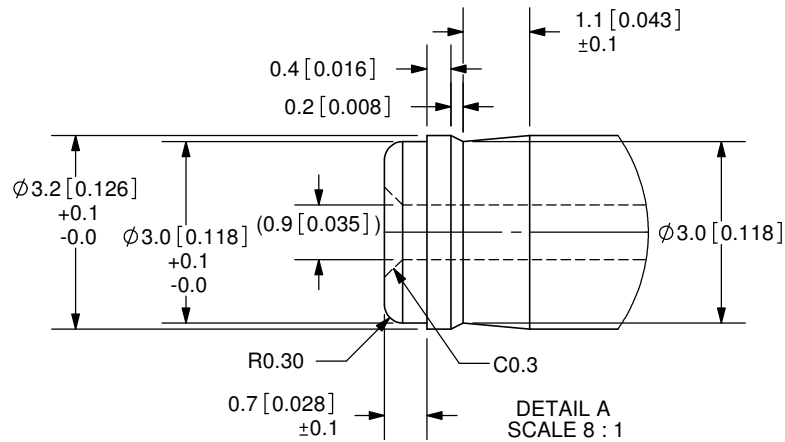

TOLERANCE:  
X.X ±0.2mm  
X.XX ±0.1mm  
X.XXX ±0.05mm

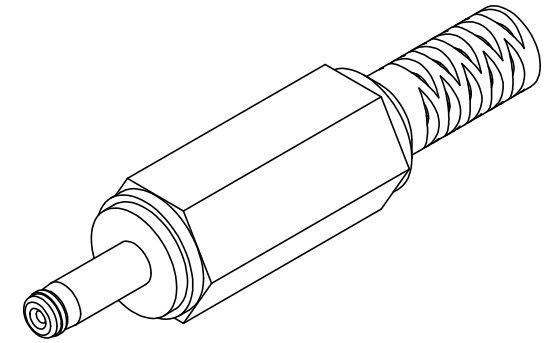
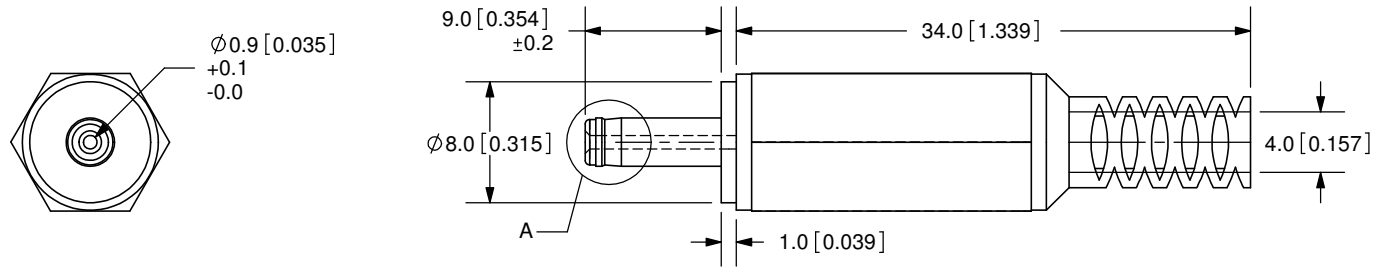

**SPECIFICATIONS:**  
RATING: 16V DC @ 2.5A  
INSULATION RESISTANCE: 100M OHMS MIN: 500V DC  
VOLTAGE WITHSTAND: 500V AC R.M.S. FOR 1 MINUTE  
LIFE: 5,000 CYCLES



20050 SW 112th Ave.  
Tualatin, OR 97062  
Phone: 503-612-2300  
800-275-4899  
Fax: 503-612-2383  
Website: www.cui.com

	MATERIAL	PLATING
COVER	PVC	Black Color
PIN	Brass	Nickel
BARREL	Brass	Nickel
TERMINALS	Brass	Nickel
TIP INSULATOR	POM	Black Color

TITLE: DC POWER PLUG		REV: A
PART NO. PP-017		UNITS: MM [INCHES]
DRAWN BY: ZRJ	APPROVED BY:	SCALE: 2:1

PC FILE NAME:  
PP-017

COPYRIGHT 2007 BY CUI INC.